

**DECORATIVE CAP**

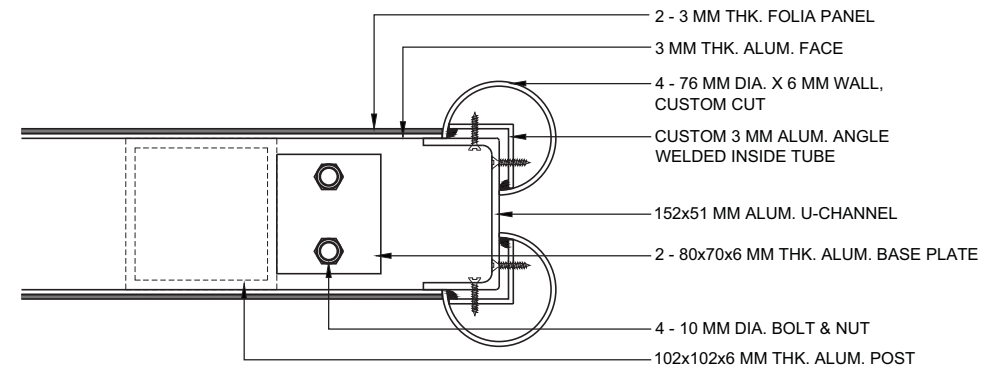

**SECTION B**

**NOTES:**

1. ENGINEERING CERTIFICATION REQUIRED FOR ALL FOOTINGS AND FOUNDATIONS SPECIFIC TO EACH LOCATION WHERE SIGNAGE IS TO BE ERECTED. FOOTINGS AND FOUNDATIONS ILLUSTRATED ARE RECOMMENDATIONS ONLY.
2. FOR ALL SIGNS SITE SPECIFIC DRAWINGS ARE REQUIRED PRIOR TO INSTALLATION. DRAWINGS MUST SHOW: MESSAGING DIRECTIONS AND LAYOUT, SIGN LOCATION AND CONTEXT REFERENCE, AND FOOTING / FOUNDATION ENGINEERING CERTIFICATION.
3. ALL MEASUREMENTS ARE IN MILLIMETERS UNLESS STATED OTHERWISE.